



Round Bale Hay Storage

Raymond L. Huhnke
Extension Agricultural Engineer

Large round bales were introduced in Oklahoma in the early 1970s. One of the reasons for the popularity of this hay package was its low-labor demand. Harvesting and storing round bales only requires one to two people; whereas, two to four people are often needed to harvest and store small square bales. Also, large round bales have fewer storage requirements. In most cases, square bales must be stored under cover and in an enclosed barn. Round bales, however, are often stored outside and unprotected because their shape enables them to shed precipitation. Still, there are many uncertainties about projected storage losses in exposed large round bales and the economic benefits of providing some type of protection.

Generally, the value of a storage system depends on the projected hay loss while in storage and the price of hay when sold or used. Table 1 shows the dollar value loss of hay based on a percentage of storage loss over a range of hay prices. For example, if hay with a market price of \$80 per ton has a 20 percent loss during storage, the value of the hay lost would be \$16 per ton. This cost of hay value lost added to the cost of the storage system, such as an enclosed barn, gives the total storage cost, which can be used to compare various types of storages. One of the biggest problems in determining the total storage cost of a system is estimating the loss of hay value during storage.

Bales Stored Outside and Unprotected

Research has shown that storage losses in large round bales stored outside and unprotected can be far greater than hay producers realize. Quality indicators such as acid detergent fiber and dry matter disappearance can be adversely affected over 10 percent. Dry matter losses can reach 50

Table 1. Value of hay lost in storage.

Storage loss (%)	Hay price (per ton)				
	\$40	\$60	\$80	\$100	120
5	2	3	4	5	6
10	4	6	8	10	12
15	6	9	12	15	18
20	8	12	16	20	24
25	10	15	20	25	30
30	12	18	24	30	36
35	14	21	28	35	42
40	16	24	32	40	48

Note: Does not include losses associated with shrinkage or reduced quality.

Oklahoma Cooperative Extension Fact Sheets
are also available on our website at:
<http://www.osuextra.com>

percent depending on bale quality, storage conditions and length in storage (Table 2). The lower value of each range represents well-formed bales located in areas such as northwestern Oklahoma with low rainfall (less than 25 inches annually) and low relative humidity. The higher values are for areas such as southeastern Oklahoma with high rainfall (greater than 40 inches annually) and high relative humidity.

Severe deterioration is usually confined to the outside two to eight inches of the bale. Depending on the bale's diameter, just two inches can represent over 10 percent of the bale's dry matter (Table 3). An eight-inch weathered layer represents a significant volume even in the largest round bale packages. The depth or thickness of weathering depends on many factors, including amount of rainfall and environmental conditions (temperature and humidity) during the storage period, the hay type and condition when baled, and bale shape and density.

Bale Density

Bales should be well-shaped and as dense as possible. Limited research indicates storage losses for variable-chamber bales may be slightly less than fixed-chamber bales. One of the important keys to reducing weathering is the tightness of the outer layer of the bale. Moisture penetration and bale deterioration are inversely proportional to the tightness of the outer two to six inches. The tighter the outer layer, the lower the losses regardless of whether the bale was formed using

Table 2. Percent dry matter loss of round hay bales.

Storage Method	Storage Period	
	Up to 9 months*	12-18 months
Exposed		
Ground	5-20	15-50
Elevated	3-15	12-35
Covered		
Ground	5-10	10-15
Elevated	2-4	5-10
Under roof	2-5	3-10
Enclosed barn	less than 2	2-5

* If used before spring warm-up.

Table 3. Amount of dry matter in outer layers of large round bales.

Bale Dia., ft.	Outer Layer Depth			
	2"	4"	6"	8"
	% dry matter loss			
4	16	31	44	56
5	13	25	36	46
6	11	21	31	40
7	9	18	27	34
8	8	16	23	31

a variable or fixed-chamber baler. Outer layer “tightness,” or density, is not easy to measure. One rule of thumb is to push on the outer surface of a newly-formed bale with the palm of your hand. If you can depress the surface more than about a half-inch, the bale could undergo significant storage losses when placed outside and unprotected. If using sisal or plastic twine, wraps should be no greater than eight inches (preferably six inches) apart on the bale. This does, however, require additional time and expense during baling. If bales are stored outside, the added time and expense are easily justified. Research shows net-wrapped bales have storage losses similar to the standard plastic or twine wrap when the outer layers are the same density.

Environmental Conditions

The amount of precipitation that falls on unprotected bales can affect storage losses. However, precipitation alone is not a good indicator of projected losses. In recent studies by Oklahoma State University researchers, storage losses were found to be related to precipitation combined with air temperature and humidity. Much of the dry matter loss associated with outside storage is the result of microbial respiration, where carbohydrates in the plant tissue plus oxygen are converted to carbon dioxide, water, and heat. Extended periods of warm, humid, and cloudy conditions with abundant rainfall are favorable for microbial activity, resulting in greater losses of forage dry matter and quality than in periods of cool, dry, and sunny conditions. To minimize storage losses, bales stored outside and unprotected should be used by early spring, before the air temperature, humidity, and precipitation significantly increase. In Oklahoma, bales should generally be used before March 1.

Storage site

The storage site is another important consideration in reducing bale losses. Select a site that is not shaded and is open to breezes to enhance drying conditions. The site should also be well-drained to minimize moisture absorption into the underside of the bales. As much as 12 inches of the bottom of a bale can be lost through moisture absorption resulting from the wicking action. Compare estimated losses for ground versus elevated storage provided in Table 2. Ground contact can account for over half of the total dry matter losses. Where practical, keep bales off the ground using low cost, surplus materials such as discarded pallets, racks, fence posts, railroad ties, and used tires. Another alternative is to use a layer of crushed rock about six inches deep to ensure good drainage within and around the storage site.

Orientation

Bales should be stored in rows, buffed end-to-end, and oriented in a north/south direction. The combination of the

north/south orientation and at least three feet between rows will provide for good sunlight penetration and air flow, which will allow the area to dry faster after a rain. Vegetation between rows should be mowed. Research has shown that orientation is a minor consideration if the bales are used before early spring because the losses are relatively small until that time. If stored into the summer, bales oriented in an east-west direction can experience severe deterioration on the north-facing surface.

Covers

Large, round bales stored outside and covered with plastic or canvas usually sustain much less deterioration compared to unprotected bales (Table 2). As shown in Table 4, the amount of covering per bale varies depending on the storage configuration. A single bale can require as much as 63 square feet to cover its top. If bales 5-foot diameter by 5-foot long are stacked three high, the size of the covering can be as low as 13 square-feet per bale.

Covering materials range in price from \$0.06 per square foot for a 6-mil black polyethylene or plastic to over \$0.75 per square foot for a tarp. To determine the cost of covering round bales, multiply the area of coverage (from Table 4) by the cost of the covering. Assuming a 6-mil black plastic at \$0.06 per square foot is used to cover a stack three high and three wide the covering cost would be approximately \$1.68 per bale (28 times \$0.06). Considering the interest on the investment for money spent on plastic, the cost would increase to about \$1.75 a bale or \$3.50 per ton if the bales weigh 1000 pounds. Because plastic generally lasts only one year, the \$3.50 per ton would be an annual cost. This cost does not include a charge for labor, fasteners, tie downs, or weighty materials to secure the plastic.

Because of its relatively low cost, plastic is a very attractive alternative as a storage covering. However, plastic has several shortcomings. First, it does not “breathe.” If high moisture hay (above 20 percent) is sealed under plastic, heavy losses in dry matter and forage quality can occur due to excessive heating and mold development. Second, nonreinforced plastic requires continual maintenance. High winds can cause large tears which must be repaired as quickly as possible. For this reason, consider using reinforced plastic. It withstands punctures and tears and with proper handling and storage between uses can last over three years. To help reduce tearing in any type of covering, weight the cover along the edges and ends to allow some movement. Do not tie a cover down tight!

Under-Roof Storage

Building Design

Dry matter losses in round bales stored up to nine months in an enclosed barn should be less than two percent (Table 2). If bales are stored in an open-sided barn (roof only) for over a year, losses can range up to 10 percent. Most commercial hay producers use enclosed barns with no more than one side open to minimize dry matter loss and to maintain good hay color, which is often used as a visual indicator of quality. For Oklahoma conditions, the opening should be to the east to prevent snow and rain from blowing into the building. The storage space should be clear to eliminate working around interior poles. New buildings should be located on a well-drained site near the feeding area.

Table 4. Cover requirements for large round bale storage.

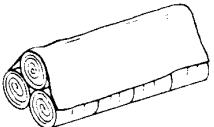
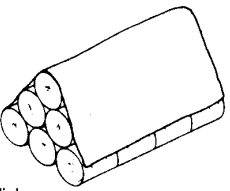
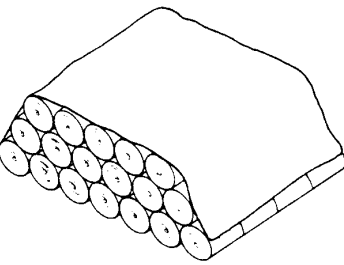
	Bale Size	
	5-ft Dia x 5 ft	6-ft Dia x 6 ft
	----- (square feet per bale) -----	
 Single Bale	55	63
 2-High, 2-Wide Pyramid	37	44
 3-High, 3-Wide Pyramid	28	33
 3-High Pyramid	13-17	16-20

There are particular sizes of buildings that work best for round bale storage. Stated building dimensions are usually only exterior measurements. Therefore, a 24-foot wide building will not provide adequate space for four 6-foot diameter bales placed side by side. Height of the storage system is another important consideration. If bales are stacked, interior height clearance should be at least two feet higher than the finished stack height (Figures 1 and 2). Table 5 shows approximate bale storage capacities for selected building sizes. Table 6 gives the approximate building space requirements based on bale size and weight.

Building Costs

Storage costs for hay stored in a building depends on the initial cost of the structure and amount of area required to store each ton of hay. Initial cost of a building depends on building style, materials, and labor costs. For turn-key buildings, labor costs often represent over 35 percent of the building price. If a producer provides a large share of the labor, the initial cost can be greatly reduced. Initial cost of construction can range from less than \$1.50 per square foot for a roof-only structure to over \$6.00 per square foot for a turn-key enclosed building.

The following factors determine the annual cost of a building:

- Depreciation (D) is the cost associated with normal life or wear out of the building. Most farm buildings will have a useful life of 15 to 20 years. Using a straight-line method, the annual depreciation is found by dividing the initial cost by the anticipated years of useful life.

- Interest on investment (I) reflects the cost of borrowing money or, if money is not borrowed, the money that could have been earned in interest if invested. For convenience, assume the interest on investment is equal to $\frac{2}{3}$ of the current annual interest rate. Investment interest over the past decade has ranged from about 7 to 11 percent while interest on borrowed money has ranged from 12 to 18 percent. Therefore, interest on investment has ranged from about 5 to 12 percent:
- Repairs (R), taxes (T), and insurance (I) for a hay storage are normally estimated at about 0.7 percent, 1.0 percent, and 0.3 percent of initial cost, respectively.

Annual building cost is determined by multiplying the initial investment by the sum of all annual DIRT percentages. For example, a proposed hay storage structure costs \$3 per square foot to construct and has an expected life of 15 years. Depreciation is equal to 6.7 percent of the initial cost (100 percent divided by 15). Money is borrowed to construct the

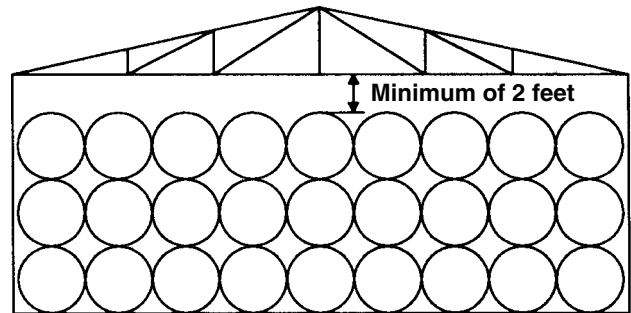

A. Bales stacked on side.

NOTE: Sidewalls must be built to withstand horizontal pressures from each row of bales.

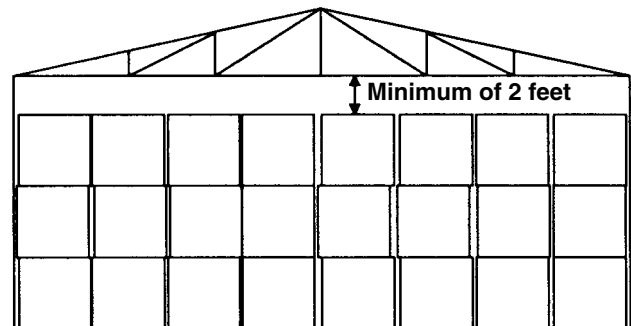

B. Bales stacked on end.

Figure 1. Under-roof storage with bales stacked vertically.

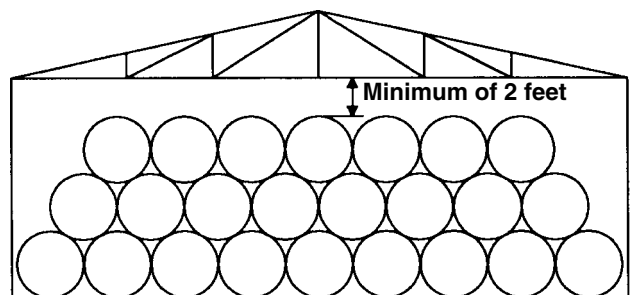

Figure 2 Under-roof storage with bales stacked in pyramid pattern.

building at an interest rate of 15 percent. Interest on investment is equal to 10 percent of initial cost (15 percent times $\frac{2}{3}$). Therefore, the annual building cost (DIRTI) is estimated at 18.7 percent (6.7 + 10 + 0.7 + 1.0 + 0.3) of the initial investment or \$0.56 per square foot (\$3 times 0.187).

The annual building cost can be converted into a cost per ton of hay by multiplying it by the building space requirements. If bales 5-foot diameter by 5 feet long weighing 1,000 pounds were vertically stacked, three high, in a 36 foot by 64 foot building, about 231 bales could be stored (Table 5) in a building providing 21 square feet per ton (Table 6). If the annual building cost was \$0.56 per square foot, annual storage cost would be \$11.76 per ton (21 times \$0.56).

Total Storage Cost

The total storage cost is the sum of the storage system (such as covers and buildings) and the cost of the projected losses while bales are in storage. Using the results of the previous building example, the total storage cost per ton of \$80 alfalfa hay with an estimated in-barn storage loss of two percent (\$1.60 per ton) for less than nine months storage period would be \$13.36 per ton (\$11.76 per ton building cost plus \$1.60 per ton loss in hay value).

If the bales were stored under a plastic cover, storage cost with an estimated eight percent (\$6.40 per ton) dry matter loss would be about \$10 per ton (\$3.60 per ton plastic cost plus \$6.40 per ton loss in hay value). Note: This does not include the costs for labor or materials to secure the cover.

If the same bales were stored outside uncovered, loss of hay value could be as much as 10 percent or \$8 per ton. This assumes the bales are well-shaped with a tight outer layer, but in contact with the ground. If elevated, the dry matter loss can be less than four percent or \$4 per ton.

With estimated storage costs of \$13.36 per ton for inbarn storage, \$10.00 per ton for covers, and \$4.00 to \$8.00 per ton for no protection, it would appear that providing protection is not cost effective. However, these estimates do not include the losses in quality or consider the end user. Commercial hay producers could have difficulties marketing hay to dairies if bales are stored outside and unprotected, especially during periods of surplus hay supplies. If the hay producer is going to feed this hay to his/her own beef herd, then the losses associated with bales stored outside and unprotected may not be a major concern.

Summary

All forages packaged in large round bales benefit from protection while in storage. However, there are several factors that must be considered in justifying the cost of providing this protection. These factors include hay value, projected in-storage losses, local environmental conditions, and where the hay will be used. If round bales are stored outside and unprotected, losses can be greatly reduced by storing only those bales that are well-shaped with dense outer layers; keeping bales off the ground to eliminate wicking; and using these bales before spring warm-up to avoid excessive weathering.

Table 5. Large round bale storage capacities.

Building Size	Vertical Stack (Figure 1) ^a				Pyramid Pattern (Figure 2) ^a			
	5-ft Dia x 5 ft		6-ft Dia x 6 ft		5-ft Dia x 5 ft		6-ft Dia x 6 ft	
	2-high	3-high	2-high	3-high	2-high	3-high	2-high	3-high
	Number of bales				Number of bales			
26' x 64'	110	165	88	132	99	132	77	99
32' x 64'	132	198	110	165	121	165	99	132
36' x 64'	154	231			143	198		
38' x 64'			132	198			121	165
42' x 64'	176	264			165	231		
44' x 64'			154	231			143	198
46' x 64'	198	297			187	264		
50' x 64'			176	264			165	231

^a Assumes about 4 feet of unused space at one end.

Table 6. Building space requirement for large round bales.

Bale weight, lb	Vertical Stack (Figure 1)				Pyramid Pattern (Figure 2)			
	5-ft Dia x 5 ft		6-ft Dia x 6 ft		5-ft Dia x 5 ft		6-ft Dia x 6 ft	
	2-high	3-high	2-high	3-high	2-high	3-high	2-high	3-high
	Square feet per ton				Square feet per ton			
600	51	34			55	39		
700	44	29			47	33		
800	38	26	46	32	41	29	49	36
900	34	23	41	28	36	26	44	32
1000	31	21	37	26	33	23	40	29
1100	28	19	34	23	30	21	36	26
1200	26	17	31	21	27	20	33	24
1300			29	20			30	22
1400			27	18			28	20
1500			25	17			26	19
1600			23	16			25	18

Oklahoma State University, in compliance with Title VI and VII of the Civil Rights Act of 1964, Executive Order 11246 as amended, Title IX of the Education Amendments of 1972, Americans with Disabilities Act of 1990, and other federal laws and regulations, does not discriminate on the basis of race, color, national origin, sex, age, religion, disability, or status as a veteran in any of its policies, practices or procedures. This includes but is not limited to admissions, employment, financial aid, and educational services.

Issued in furtherance of Cooperative Extension work, acts of May 8 and June 30, 1914, in cooperation with the U.S. Department of Agriculture, Samuel E. Curl, Director of Cooperative Extension Service, Oklahoma State University, Stillwater, Oklahoma. This publication is printed and issued by Oklahoma State University as authorized by the Dean of the Division of Agricultural Sciences and Natural Resources and has been prepared and distributed at a cost of \$.20 per copy. 0703.